

*Rain Soft*®

MODEL 9590  
REVERSE OSMOSIS  
DRINKING WATER SYSTEM

INSTALLATION  
INSTRUCTIONS



TESTED AND CERTIFIED UNDER ANSI/NSF STANDARD 58  
FOR REDUCTION OF TOTAL DISSOLVED SOLIDS (TDS),  
TURBIDITY, HEXAVALENT CHROMIUM, TRIVALENT  
CHROMIUM, FLUORIDE, LEAD, MERCURY AND SELENIUM.

## RAINSOFT MODEL 9590 R.O. SYSTEM COMPONENTS

1. **#9528 SEDIMENT PRE-FILTER:** A water filter that removes large particles and sediment over 20 microns in size from the supply stream. The filter cartridge requires periodic replacement depending upon the quality of the water supply.
2. **#9564 R.O. CARTRIDGE:** A semi-permeable cellulose tri-acetate (CTA) R.O. membrane cartridge.
3. **#9518 (POLYOLEFIN) STORAGE TANK:** An R.O. storage tank with a bladder, that will hold R.O. water on one side of the bladder and pressurized air on the other side.
4. **#9798 ACTIVATED CARBON POST FILTER:** An activated carbon filter to remove unwanted tastes, odors and other impurities. The filter requires periodic replacement depending upon the quality of the water supply.

### FEATURES

1. **DRAIN SHUT-OFF VALVE:** A control valve that shuts off the inlet water when pressure in the storage tank equals approximately 75% of inlet water pressure.
2. **PRESSURE RELEASE VALVE:** A control valve that can be adjusted to allow the drain to run continuously, where this is advisable.
3. **ADJUSTABLE DRAIN:** A screwdriver adjustment to control drain flow rate. Drain flow rate can be increased or decreased to obtain optimum performance on any water supply.
4. **SELF CLEANING DRAIN RESTRICTOR AND FAST FLUSH:** Rotate the drain restrictor assembly 90° to fast flush the system for five minutes. Rotate the drain restrictor another 90° to drain restrictor position #2 to automatically clean out the drain restrictor and return to pre-set drain flow. Reverse this procedure several times each week.
5. **TDS MONITOR PORT:** Available port for installation of optional TDS meter.

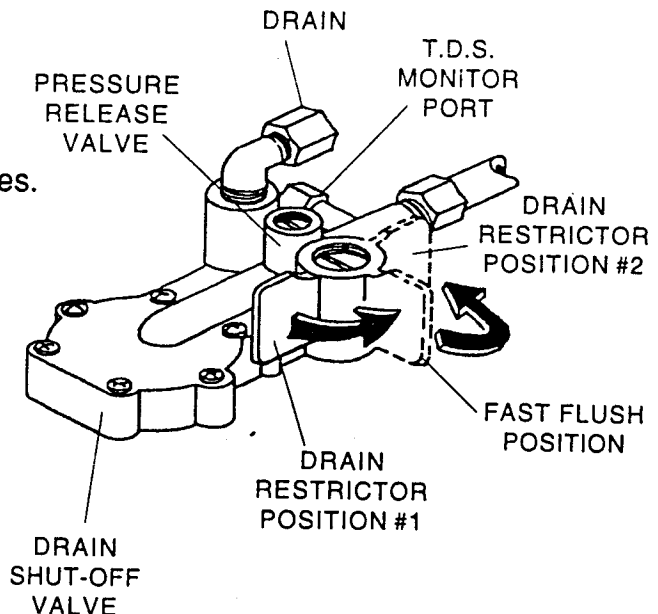

## 24 HOUR PRE-INSTALLATION PREPARATION RAINSOFT MODEL 9590 REVERSE OSMOSIS SYSTEM

The following 24 hour pre-installation should be performed prior to the systems installation date.

THIS DIAGRAM SHOWS A TYPICAL 24 HOUR PRE-INSTALLATION TEST RACK. THIS SET-UP MAY BE REPEATED FOR SEVERAL STATIONS

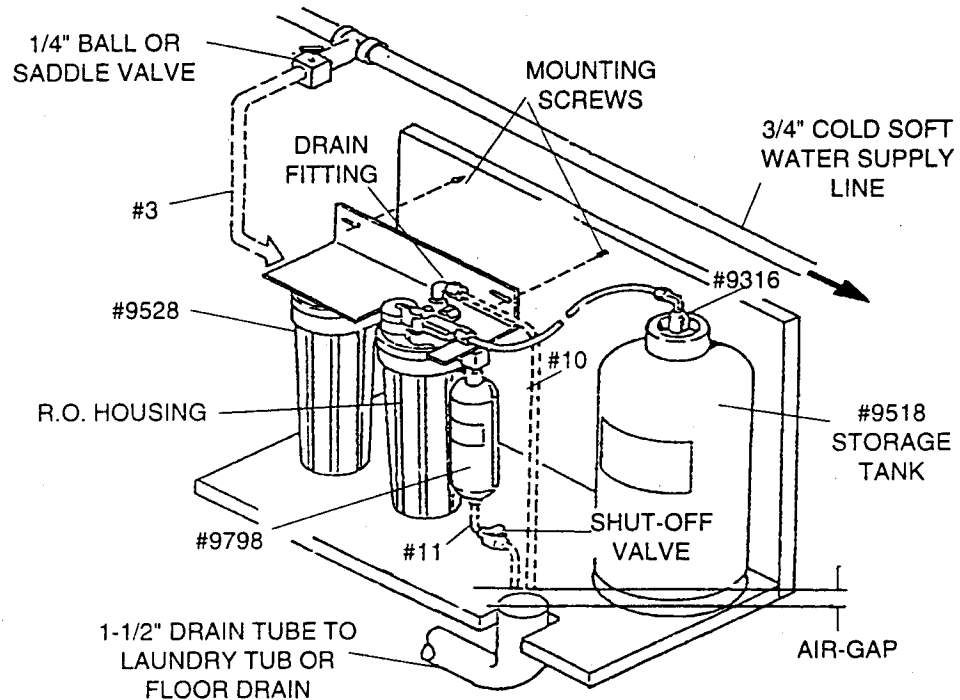

1. Remove R.O. cartridge (#9564) from sealed bag and install into R.O. housing.
2. Connect tubing #3 to a cold (preferably soft) water line, and the "in" side of the #9528 pre-filter.
3. Install a 1/4" O.D. x 1/8" NPT plastic drain fitting and connect a 1/4" O.D. line #10 from the drain fitting and run it to the drain.
4. Close the storage tank valve #9316. Install a 1/4" NPT x 1/4" O.D. minimum fitting to the outlet side of the #9798 post filter. Connect a 1/4" O.D. minimum line (#11) to the drain. Install a shut-off valve on line #11. Open the shut-off valve.
5. Turn on the water pressure to the unit. You may change the drain flow rate by turning the drain adjustment screw using a small screwdriver. The drain adjustment screw is located inside the drain restrictor (shown at right). Turn the drain adjustment screw clockwise to decrease drain flow and counterclockwise to increase drain flow. **CAUTION:** Do not completely remove the drain adjustment screw, 1 or 2 full turns is all that is needed. Do not tighten the drain adjustment screw down or completely close off the drain flow.

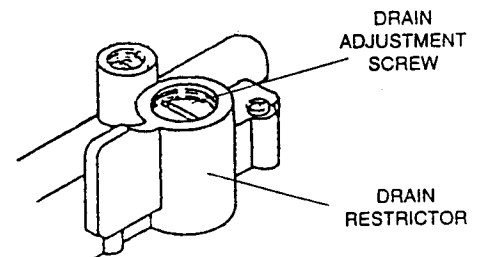

The ideal drain flow should be 3 to 6 times greater than the product flow rate at line #11.

6. Measure the quality and quantity of the water coming from the end of tubing #11. Check the TDS of the water.
7. When quality is produced (75% TDS reduction or better) open the storage tank valve #9316, close the shut-off valve on line #11, and allow the storage tank to fill overnight. In the morning there should be no water running at the drain, tubing #10.
8. Check all connections for leaks and correct if necessary.
9. Close the inlet valve to turn off the water pressure. Close the storage tank valve #9316. Disconnect line #11 from the post filter. Disconnect and drain the rest of the system. Deliver storage tank full of R.O. Water.
10. Arrange the installation appointment with the customer. Ask the customer to clean out the area where the installation will be made. This will save you time and save the customer from possible embarrassment. It will also give the customer some time to notice any leaks before you begin your work there.

### INSTALLATION REQUIREMENTS

Do not install system where water is microbiologically unsafe or of unknown quality. Test and make a record of the water to be treated. It must meet the following conditions:

- A. Working pressure: 40-100 PSI. If line pressure exceeds 100 PSI a pressure regulator must be installed ahead of the unit.
- B. No Iron, Manganese or Sulphur.
- C. pH: 3 to 9.
- D. Temperature: 50° to 85° F.
- E. TDS: Not greater than 1000 PPM.

Install in an area not affected by extreme heat, cold or the elements. The area must allow all components to be serviced quickly and where it is easy for the customer to change cartridges and flush the R.O. cartridge.

When full, the system will weigh approximately 36 lbs. Plan to mount it on a firm surface.

Note: This system must be installed in accordance with all applicable state and local laws and regulations.

### HARD WATER

If water is hard, calcium and magnesium carbonates can precipitate or "scale" on the membrane. This scaling will eventually block the flow through the membrane. Scaling is a complex function of hardness, pH, alkalinity, temperature and flow ratios.

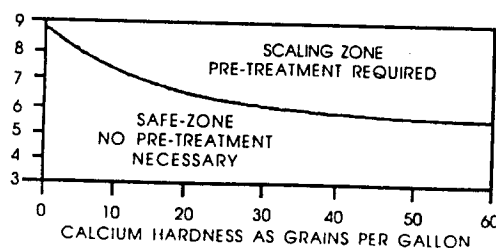

**CAUTION: USE PLASTIC FITTINGS WITH TEFLON TAPE ONLY.**

1. PROVIDE AN INLET VALVE

Install an inlet valve between the existing cold water shut-off valve and the kitchen faucet in a manner that conforms to plumbing codes.

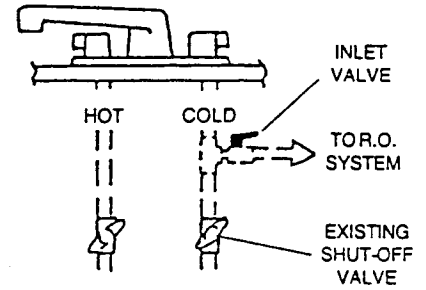

2. CONNECT SYSTEM

Use inserts and sleeves, as required, on all connections. Use quick disconnect fittings or add extra tubing so the system can easily be removed to make changing cartridges easier. Coil the extra tubing so it's out of the way.

3. PROVIDE A DRAIN OUTLET

This can be through any entry to the drain system, in a manner that conforms to plumbing codes.

Plumbing codes require an air-gap into the drain system. This is to prevent a back syphoning which could cause contamination of the water supply.

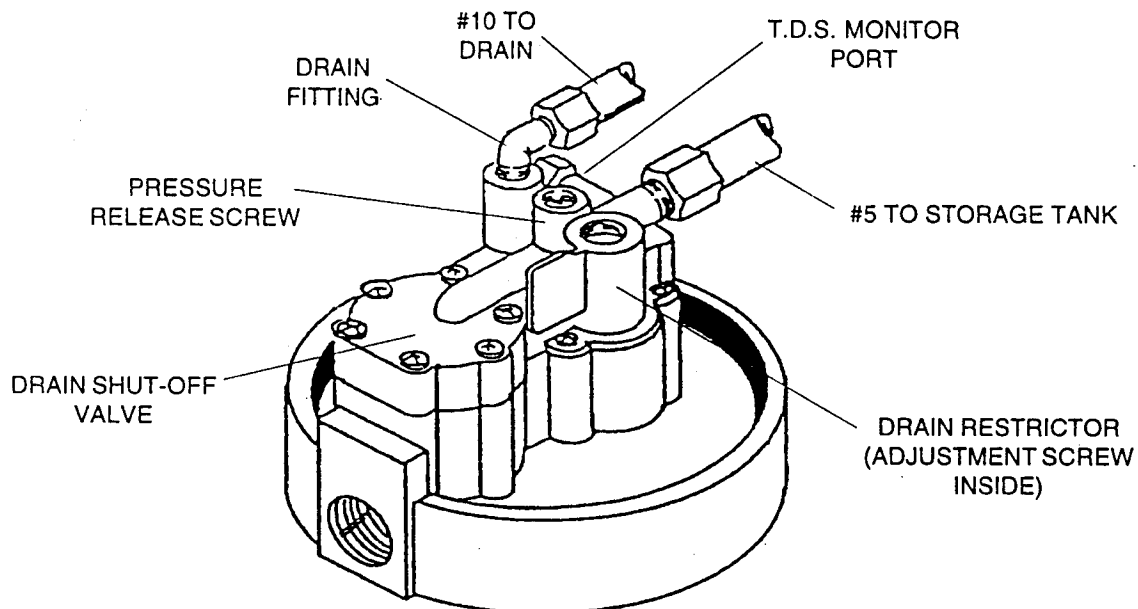

## MODEL 9590 R. O. SYSTEM

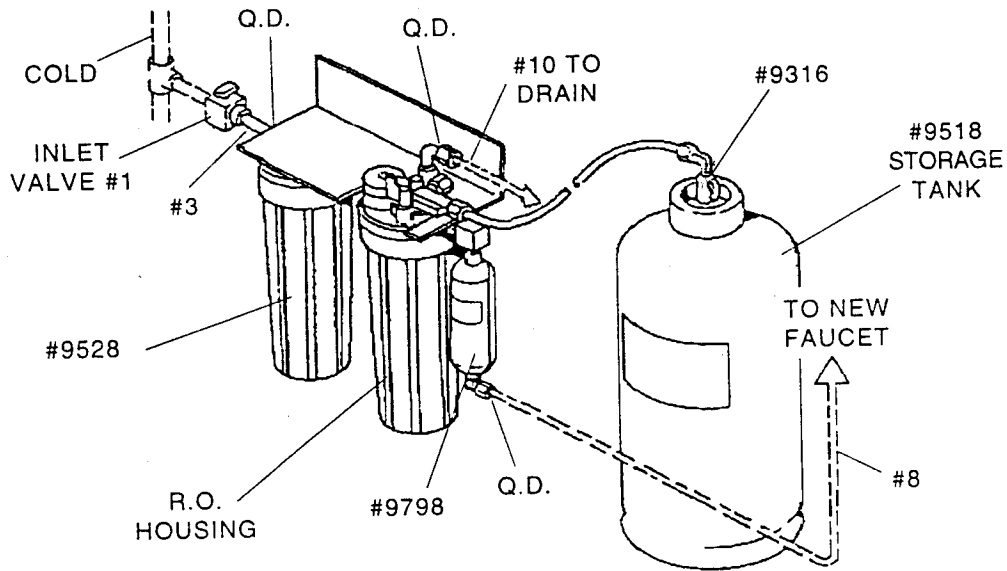

**DIAGRAM 2**

Q.D. = QUICK DISCONNECT FITTINGS

R.O. HOUSING CONTAINS #9564 R.O. CARTRIDGE

#9528 PRE-FILTER ASSEMBLY = #9521 HOUSING & #9547 CARTRIDGE

### **REFER TO DIAGRAM #2**

- A. Connect minimum 1/4" O.D. tubing (#3) from inlet valve #1 to the inlet side of the pre-filter (#9528).
- B. Connect 1/4" O.D. tubing (#10) from the drain fitting to the drain through an air-gap or approved air-gap faucet. Note: Air-gap faucet may require local code approval. If an air-gap faucet is used, connect it in accordance with its instructions. CAUTION: Be sure the air-gap faucet does not leak when the system is fast flushed.
- C. Connect 3/8" O.D. tubing (#8) from the outlet side of the #9798 post carbon filter to the faucet, and to the refrigerator, if desired.
- D. Install a T.D.S. meter (not included) if desired.

E. Open inlet valve #1, wait until water runs to drain then open valve #9316. The system is factory set for the drain shut-off valve to operate. If you desire the system to have a continuous running drain, then turn the pressure release screw, using a small screwdriver, 1 full turn counterclockwise. The pressure release screw is located on top of the product port (shown at right). CAUTION: Do not completely remove the pressure release screw. If it is re-closed, do not overtighten.

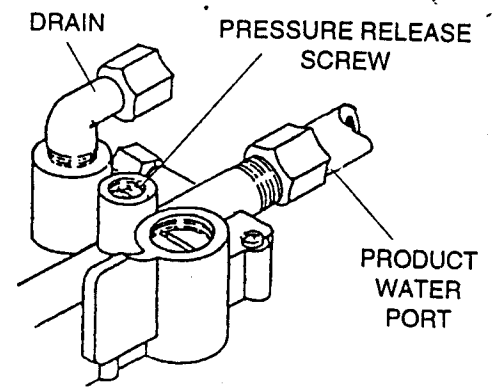

F. Check for leaks and correct, if necessary. Open the faucet to drain the tank. This will flush out any remaining disinfectant.

G. Clean-up! No installation is complete until the entire area is clean.

H. Customer Orientation:

1. After clean-up explain the operation of the system to the customer.
2. Explain your testing procedures.
3. Explain which parts will require servicing and the costs for service.
4. Explain guarantee policy.
5. Explain where shut-off valve #1 and #9316 are and what to do in the event of a leak.
6. Review maintenance procedures with customer.
7. Explain free test policy.
8. Instruct owner to run the first two full tanks of R.O. water down the drain.

I. Check Back! It is always a good idea to contact the customer within one week after the installation to verify satisfaction or to answer any questions the customer might have.

**MODEL 9590 REVERSE OSMOSIS SYSTEM SPECIFICATIONS**

System Weight: Approximately 36 lbs. when full.  
 Storage Tank Size: 9" diameter x 18" high.  
 System Size: 13" X 5" X 13".

Specifications based on the following conditions: 750 PPM tap water, 50 PSI, 77°F, and pH 7.

Production Rate: 10 GPD.  
 Operating Pressure: 40-100 PSIG.  
 Drain Flow Rate: Varies - Usually 3 to 6 times product flow rate (See chart below).

<u>DRAIN WATER</u>	<u>RATIO</u>	<u>PRODUCT WATER</u>	<u>DRAIN FLOW RATE ML/MIN.</u>	<u>APPROX. OUNCES PER MIN.</u>
2	:	1	55 .....	2
3	:	1	80 .....	2-3/4
4	:	1	105 .....	3-1/2
5	:	1	130 .....	4
6	:	1	155 .....	5
7	:	1	180 .....	6